

## Information on your Telephone – For Your Records

Manufacturer \_\_\_\_\_

Date of Original Manufacture \_\_\_\_\_

Drawing Reference \_\_\_\_\_

\_\_\_\_\_

\_\_\_\_\_

\_\_\_\_\_

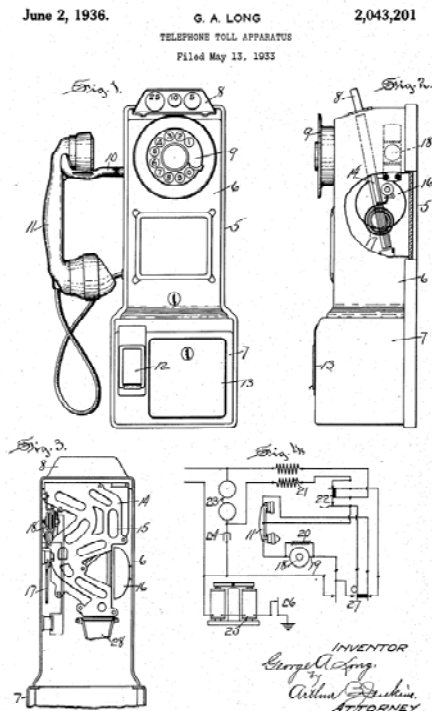

One of the original patents --- US 2,043,201

This Telephone is Property of

\_\_\_\_\_

# 3 Slot Payphone Controller

The 3 Slot Payphone -- Part of American History

## Building a Coin Relay Controller – Version S1BX

### Instruction Manual and Safety Precautions

It is very important that for your safety and well being that you fully understand all the safety precautions BEFORE you start building this controller. Read this booklet completely before you start this project.

When telephone companies installed a pay phone they connected a ground wire from the metal shell of the telephone to a known good ground, a cold water pipe (assuming you do not use plastic water pipe!) or a ground rod. You should attach a ground wire of #16 or larger gauge wire from the metal case of your payphone and connect it to a known good ground.

This circuit uses a 24 Volt AC plug in UL APPROVED transformer and a fuse, do not substitute. The power supply for the coin relay is about 75 Volts DC and can cause a shock. **DO NOT** touch the circuit when it energized and make sure you understand precautions with working with high voltage. **You can get a shock!** If you are not sure about safety around high voltages, do not build this project and do not install it.

**DO NOT IGNORE THESE IMPORTANT SAFETY INSTRUCTIONS – THEY ARE FOR YOUR SAFETY**

[oldphoneguy.net](http://oldphoneguy.net)

## The Controller

The Controller will collect OR return coins that are deposited. There is only one choice in the simple controller, return is suggested. (Reverse the leads to the Coin Relay to control the collect or return function.)

Power is provided by a 24 Volt AC wall transformer. This is changed to DC. The power supply provides approximately 35 Volts DC and 100 Volts DC. The Coin Relay has a must operate specification of 60 Volts DC with a full hopper of coins.

This controller is for use on more modern pay phones with a set of contacts on the Coin Relay that short the pulsing contacts on a rotary dial, or prevent a tone dial from working. This is commonly known as "Dial Tone First". Older pay phones may not have shorting contacts that prevent dialing.

In the olden days, pay phones used ground start telephone lines with all the "smarts" in the central office. This controller will simulate that, but only to a very simple extent.

Have you read the safety information? Do you fully understand it? Proceed only if you can answer yes to these two questions!

Here is a breadboard picture of what you are going to build. You should do a breadboard FIRSAT then build it

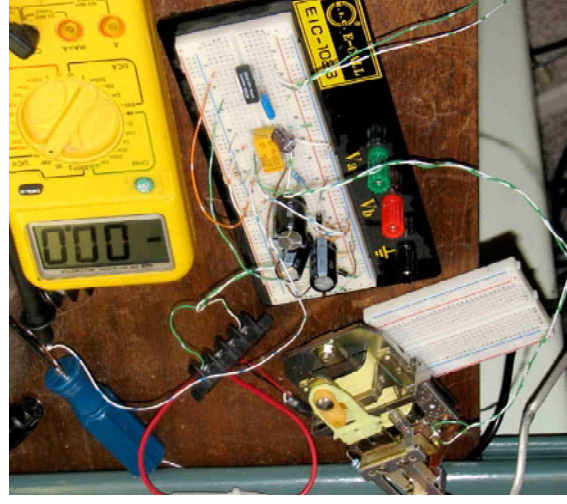

Thanks to Bill Geurts for the picture.

2

## Notes

Remember – High Voltage Can Be Dangerous

oldphoneyguynet

## Cardboard Box

This is not full size, redraw it to the proper size. Use card stock, cut on the dotted lines, put the circuit inside and glue the box together or tape it closed. For additional protection put it in a plastic bag or fully cover it in tape. Check the size first to make sure it will fit. OR, put in an external box outside the phone. Cardboard box ONLY for use internally in the phone. The picture below has 2 boxes.

3 Slot Pay Phone – Circuit Pack  
To Fit on Right Side of Single Coil Coin Relay

	<b>You may need to custom size this for your phone</b>		<i>Or in Coin Vault In Early AE or All WE &amp; NE Phones</i>
<i>To Fit in top of AE Phones Next to Coin Box</i>	<b>HIGH VOLTAGE DO NOT OPEN 1 x 2.75 x 2.5</b>	4202	<b>HIGH VOLTAGE DO NOT OPEN</b>
	<b>Most Automatic Electric Payphones</b>		<b>With DB Connector and no leaf spring connector</b>

	<b>You may need to custom size this for your phone</b>		<i>Or in Coin Vault In Early AE or All WE &amp; NE Phones</i>
<i>To Fit in top of AE Phones Next to Coin Box</i>	<b>HIGH VOLTAGE DO NOT OPEN 1 x 2.75 x 2.5</b>	4202	<b>HIGH VOLTAGE DO NOT OPEN</b>
	<b>Most Automatic Electric Payphones</b>		<b>With DB Connector and no leaf spring connector</b>

Cut on Dots  
10

## Basic Connection Drawing For Placing Circuit in Telephone

Location of cardboard box For AE Phones with DB Plug For Western or Northern may not fit, Or place in Coin Vault area and use Tuna can for coins. OR, use an external box and run the coin relay/switch out on a pair of wires

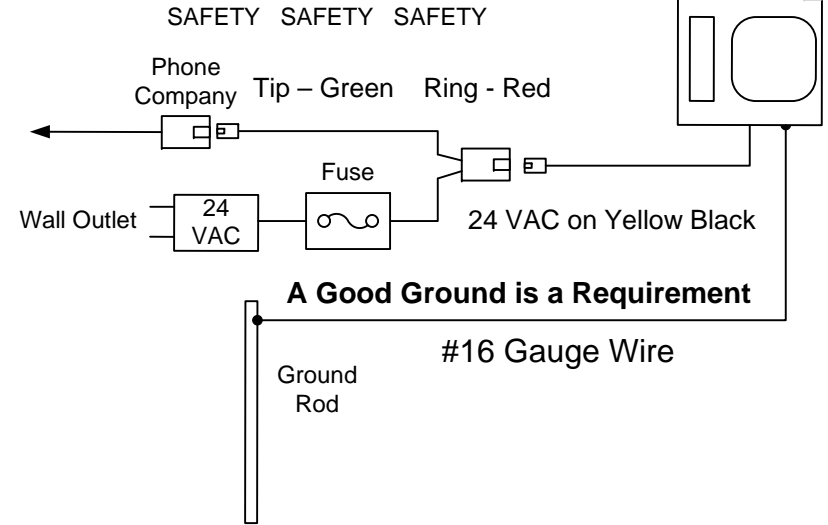

The drawing illustrates how to connect the 24 VAC to the pay phone, if you were putting the circuit inside the phone. If you mount it externally, you reverse this and run the coin relay out on the yellow back wires. The assumption is that you are using a modular cord. Of course you can use twisted pair cable or just about any other type of wiring.

The fuse should be put in a small box outside the telephone. Cut the connector off the end of the power supply, run it into a small box and use in in-line fuse holder with a ¼ or ½ amp fuse.

If you experience hum on the telephone when the power supply is in use, run a separate set of wires for the AC power, or locate your circuit outside the phone.

This circuit will fit inside an AE pay phone with the DB type of plug. A fold up cardboard box is shown in this booklet, you should re-draw it on card stock (the thickness of an index card) cut it out and use it contain your circuit. It will fit on the right hand side of a single coil coin relay.

### 3 Slot Coin Telephone – Simulator

Version 5.2 CRA – Circuit Board Schematic

All Resistors 1/2 Watt -- DR is 1N4004 -- Fuse 3AG or AGC  
If space permits board to be marked – DANGER HIGH VOLTAGE

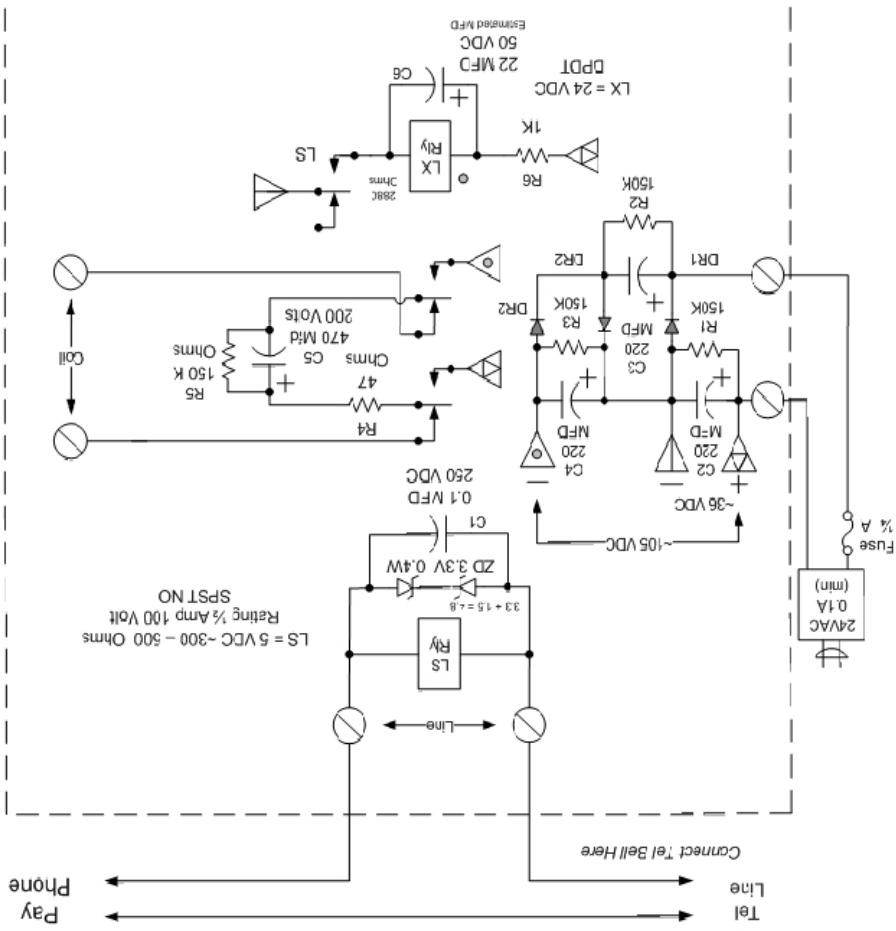

LS Relay



Screw Terminals



LX Relay  
DS2Y-S-DC24V DPDT 24V 2A Relay  
Polarized - Do Not Fuse

Designed by Colin T. Chambers

### Suggestions on Parts

If you order from Jameco, the suggested relay is:

DIP Relay

106463 201A05 Excel Cell Elect. SPST-NO 5VDC 500 Ohms  
They also have the 24 VAC 500 MA transformer

From Futurlec the 24 volt relay is:

DS2Y-S-DC24V 24 V 2880 Ohms DPDT DIP

Other parts are cheap there, but no 5V relay, They also have the HV Electrolytics.

The cost of both of these relays is under \$7.00.

Surplus parts dealers, such as All Electronics, may have similar items at a lower cost.

A fuse is shown on the diagram. You should use two fuses, one inside the telephone and one on the power supply outside the telephone.

### Suggestions on Mounting the Circuit in the Phone

The box size may need to be adjusted for your phone and it is dependent on where you mount it. Automatic Electric phones with the DB style plug between the upper and lower housings have space next to the coin relay.

Older phones with the long leaf spring connectors between the housing may not have the space. Most Western Electric and Northern Electric phones lack that space because of the springs.

You can mount the circuit in the coin box and use a small tin can (it makes a nice sound) if you want to collect the coins. This is why return is suggested.

Or, use an external box and run the coin relay and contact out on the

yellow and black of the mounting cord. This is the suggested solution for not AE phones or phones with leaf springs for connections between the upper and lower housing. You can use a 6 Cond Mod Cord – Pair 1 Phone Circuit, Pair 2 Bell and Pair 3 Coin Relay

Coin Relay is Coin Relay AND grounding switch.

## Power Supply:

A 24 VAC wall wart provides the power. The rating on this transformer is a minimum of 0.1 Amp. I use surplus wall warts so some are rated at 0.6 Amp. A fuse is used, just in case.

The power supply is a voltage tripler, AC is changed to DC. DC is 1.41 times the AC less the 1 volt drop for diode (a bit less drop but 1 Volt is used). Since the power used is not the maximum the transformer will supply, it will probably measure 26 Volts AC or a bit more. This works out to 35 Volts DC, times three is 100 Volts DC or a bit more.

FOR SAFETY THERE IS A 150K RESISTOR ACROSS EACH POWER SUPPLY CAPACITOR, AND A 150K RESISTOR ACROSS THE COIN CAPACITOR. THIS WILL ENSURE THEY DISCHARGE WHEN THE UNIT IS UNPLUGGED AND YOU WANT TO WORK ON THE PHONE. UNPLUG THE POWER SUPPLY FOR 1 HOUR BEFORE WORKING ON THE CIRCUIT!

The coin relay has a must operate specification of 60 VDC and this is with a load of coins, so all should be fine.

## Notes and Comments

Standard Telco Coin Relays are about 1000 ohms and are designed to work on 60 to 110 Volts DC. Private pay phones may use similar looking relays but they may be rated at 48 Volts DC or 12 Volts DC. They may or may not operate with this circuit. This circuit will not work with post pay coin relays.

This circuit has been tested with a number of pay phones and relays without any issues. The 100 Volts on the capacitor starts to fall as soon as the coin relay operates, but the "power" will make the relay operate just fine.

Incoming calls, if answered during the ringing interval may briefly operate the circuit. Relays may click, but the coin relay will not operate since no coins have been deposited. The resistor across C4 will discharge it in a short time. Do not deposit a coin upon answer of an incoming call or the coin relay may partially operate.

## Parts List

LS Relay – Line Sense – 5 VDC SPST NO Rated ½ Amp 100 VDC, Coil resistance between 300 and 500 ohms. DIP size, similar to an IC  
LX Relay – Line Hold – 24 VDC DPST 2 Amp, Coil resistance between 1500 and 2800 Ohms. NO diode on the coil, some relays may be polarized, read the data sheets.

ZD – Zener Diode – Limits voltage across LS relay. 3.3 Volts 400 mW.  
In this configuration voltage drop across relay is max 4.8 VDC.

DR – Rectifier, converts AC to DC, 1N4004, 400 PIV 1 amp

C1 – RF Filter – 0.1 MFD 250 VDC

C2 -C3 – C4 – Power Supply Filter – 220 MFD 100 VDC

C4 – Coin Relay Power – 470 MFD 200 or 250 VDC

C5 – Dial Pulse Filter – 22 or 33 MFD 50 VDC (use 22 MFD if it works)

R1 – R2 – R3 - Power Supply safe discharge – 150 K ½ Watt

R4 – Surge Current Limiter 47 Ohms ½ Watt

R5 – Coin Capacitor safe discharge – 150 K ½ Watt

R5 – Relay LX Voltage Drop – 1K ½ Watt

Box, mod cord, mod jack, 24 VAC 0.1 Amp (minimum) transformer and misc parts.

## Notes:

1. Relay LX is rated 24 VDC and will operate at 30 Volts with no problems. Resistors R5 and R6 reduce the power supply voltage of 35 VDC to about 24 VDC. Exact values of R5-R6 depend on the resistance of relay LX.

2. Resistors R1-R2-R3-R5 discharge the capacitors in about 1 hour. Unplug your AC Transformer and wait 1 hour before working on your circuit.

Suggested Parts Source: Jameco Electronics

<http://www.jameco.com> or <http://www.futurlec.com> (lower cost)

Estimated Cost about \$25.00

## Circuit Explanation

Ringer:

The ringer is connected ahead of the simulator circuit. Not all pay phones have a ringer built in, if it is built in, you need to connect is separately to a pair of wires.

Telephone Circuit:

Connected to a separate set of wires.

Coin Relay:

The coin relay and switch is connected to a separate set of wires. On older phones there may be only one switch. These would be full pre pay phones where you would put in a dime to get dial tone. This feature is not available, so if the coin relay only had one switch you could dial a call without a deposit, but since this is a hobby phone and all your friends are honest, they will read the instructions on the pay phone and deposit a dime.

If the pay phone is more modern, it will have a second set of contacts, with the second set of contacts connected in parallel with the dial pulse contacts, so that a dime deposit is necessary to allow the dial to work. These are "Dial Tone First", prior to free calls to 911 without a dime.

Off Hook Detector:

Relay LS is to sense when you pick up the handset and get dial tone. This is a very sensitive relay, and high resistance, in series with the telephone circuit. Zener diodes across the relay coil keep the voltage across the relay constant. A small capacitor across the coil and diodes prevent any noise or detection of radio signals by the diodes.

This relay is rated at 5 VDC and about 300 to 500 ohms. Typically it has only one contact that closes when current flows.

Slow Release Relay:

This is the heart of the circuit. It is an ordinary 24 VDC DIP relay (LX) with a 22 or 33 MFD capacitor across it. Because the voltage in the power supply is about 35 VDC a 1k resistor is used to "drop" the 35 VDC to 26 VDC. This relay has a resistance of about 2800 Ohms. If you use a lower resistance relay you may need to adjust values slightly.

When the contact on the LS relay closes, power is applied to the LX relay. The LX relay remains operated for a short time after the power is removed because the 22 MFD capacitor stores a small amount of electricity. Relay LS opens the circuit each time you dial, if you dial "7" then it is opened 7 times. The capacitor keeps relay LX operated during dial pulsing. The trick is select the capacitor to keep LX operated when you dial "0" for 10 pulses and release when you hang up for about 1 second or a bit less. If your relay releases during dialing, increase the size of the capacitor to 33 MFD or a bit more.

Coin Relay Power:

A 470 MFD capacitor charges with the full power supply voltage, about 100+ VDC when relay LX operates. This capacitor will operate the coin relay as soon as you hang up. THIS VOLTAGE CAN BE DANGEROUS, BE SURE YOU UNDERSTAND THE PRECAUTIONS YOU NEED TO FOLLOW. Wait for the capacitor to discharge before working on the circuit.

A 47 Ohm resistor in series with the 470 MFD capacitor is used to limit the charge current and discharge current of the capacitor. If you shorted the 470 MFD capacitor, without this resistor or charged it without this resistor, there were would be spark. This saves the relay contacts, giving them a very long life.

A 150K resistor (150,000 Ohms) is connected across the 470 MFD capacitor to discharge is in case you answer an incoming call and the switch on the coin relay has not been tripped.